

# NAIS

## HEAD SEPARATED DIGITAL PRESSURE SENSORS

# UZU4/5 Series



***1/1,000 sec.***

**THE ADVANTAGE  
OF THE FASTEST RESPONSE**



**High speed in response to the needs of the times. Breaking the 1ms barrier, the fastest in the industry.**

In response to the needs of the times, amid the continuing quest for faster and more efficient production lines, comes the **UZU4/5** series, a digital pressure sensor with a detachable head.

A response time of 1ms makes this the fastest sensor.

In addition to the high speed response time, the detachable head represents a major breakthrough in terms of ease of operation and maintenance.

### **Super fast 1ms**

Mounting the detachable head close to the detecting section minimizes piping and enables response times of 1ms, as well as greatly decreasing tact time delays. In addition, the ultra-small and light-weight design of the head means it can easily be mounted to moving sections.

## Ultra-small, extremely light head (6g) enhances excellence and convenience.

### Sensor head with operation indicators

The sensor head also has an operation indicator, so you can check output ON/OFF on the sensor head where the sensor is located. (Linked to Comparative Output 1)



### Use sensor head independently

Data can be controlled by taking the analog voltage output (1 to 5V) from the sensor head and feeding it to the digital panel meter.

### Convenient intermediate cable

Intermediate cable with connectors for connecting the sensor head and the controller make operation and maintenance easier.



Standard or flexible intermediate cables are available in 2m 6.562ft, 3m 9.842ft, and 5m 16.404ft types.

Use the flexible intermediate cable when attached to moving sections.

### Easy mounting, mobile pressure port

The head's pressure port can be rotated independently (free-turning). In addition to being easy to mount, the cable can be laid in any direction.



## A total of 10 head variations to meet all production demands.

Vacuum pressure type (0 to -101.3kPa)	Positive pressure type (0 to 1.000MPa)	Compound pressure type (-100.0 to 100.0kPa)
<ul style="list-style-type: none"> <li>M5 male thread</li> <li>R1/8 (PT) male thread/ M5 female thread</li> <li>NPT1/8 male thread/ 10-32UNF female thread</li> <li>10-32UNF male thread</li> </ul>	<ul style="list-style-type: none"> <li>M5 female thread</li> <li>R1/8 (PT) male thread/ M5 female thread</li> <li>NPT1/8 male thread/ 10-32UNF female thread</li> </ul>	<ul style="list-style-type: none"> <li>M5 female thread</li> <li>R (PT) 1/8 male thread/ M5 female thread</li> <li>NPT1/8 male thread/ 10-32UNF female thread</li> </ul>

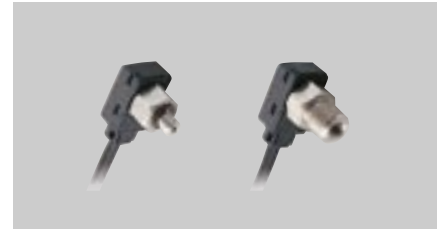

Two types of output, NPN and PNP, are available to allow use of the sensors anywhere in the world. The sensor, of course, conforms to the CE marking EMC Directive. Further, it has obtained UL recognition.



## Detachable head means layout freedom.

### Use it any way you want.

#### Light-weight, compact design

The controller inherits its light-weight compact design from the popular compact digital pressure sensor **UZU3** series. Control panel setup is low cost and requires minimal space.

#### User friendly two-color digital display

The user friendly two-color digital display changes color when output changes (ON/OFF), making it easy to check operation status at a glance. Comparative Output 1 or Comparative Output 2 can also be selected.

#### Two independent outputs and analog voltage output

In addition to two independent outputs (ON/OFF), analog voltage output (1 to 5V) is also available. Varying the output system allows you to create solutions for a wide variety of applications.

#### Two operation indicators

There are two operation indicators that light when either Comparative Output 1 or Comparative Output 2 is ON. Convenient for operation checks related to system management.

#### Sensor head auto-recognition

The head's auto-recognition function means you don't have to manually set the head type for the controller, saving you valuable planning time.



## Handy attachments for flexible controller mounting

### Supplied with a panel mounting bracket

A panel mounting bracket is enclosed to enable simple mounting of the controller onto the panel surface, thus contributing to the total cost reduction.

### DIN rail mounting bracket is available

The controller can be mounted even on a 35mm 1.378inch width DIN rail by using the optional DIN rail mounting bracket (**UZU3802**). It can be mounted in a narrow space inside of your device because it can be done from four directions.



### Usable with a panel thickness of 1 to 6mm .039 to .236inch

Since the panel thickness can be from 1 to 6mm, the controller can even be mounted on thick, resin-made panels.



### Selection from six pressure units

The pressure unit can be selected from six different systems to suit your requirement.

(The selectable pressure units differ with the sensor type.)  
 (When the pressure unit is changed, the measured pressure value and the set values are automatically converted.)

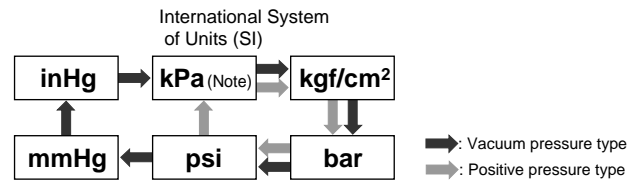

Note: 'MPa' in case of combining with **UZU521**, **UZU522** or **UZU523** positive pressure sensor head

## Full range of functions in a compact body, gives you a wide variety of control options.

The only sensor in the industry with a leak test mode.  
 Four output modes give you complete control.

### Leak test mode

It is suitable for a leak test since comparative output 1 can be set to the hysteresis mode and comparative output 2 can be set to the window comparator mode. Applying the auto-reference and remote adjustment functions simultaneously ensures an even more reliable leak test.

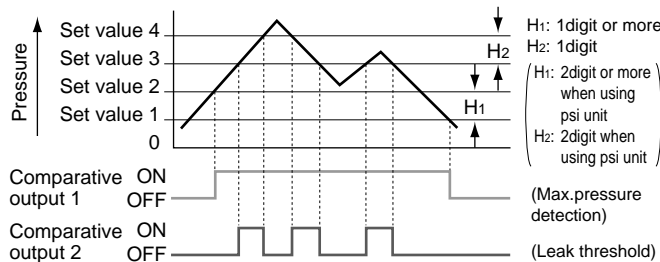

### Hysteresis mode

The hysteresis of the comparative outputs can be set arbitrarily by the set values for ON/OFF control.

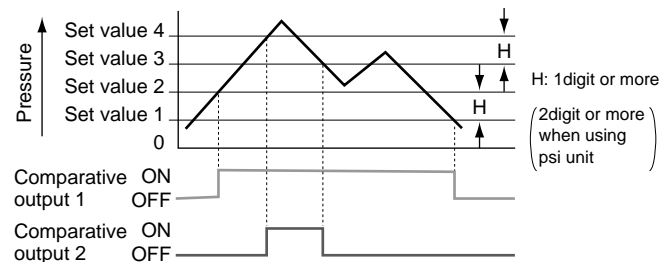

### Window comparator mode

The comparative output can be turned ON or OFF by a pressure which is within the set pressure range.

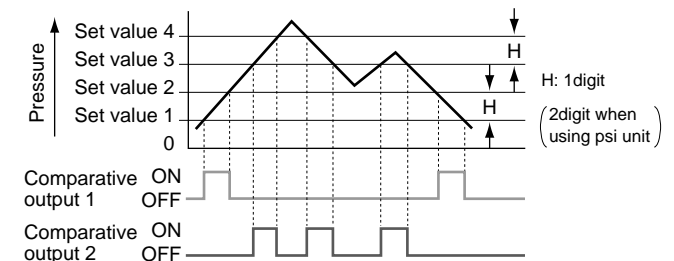

### Forced output mode

The comparative outputs are forcibly maintained at OFF level in the sensing mode, irrespective of the set values. Hence, it is convenient for only displaying the pressure value without using the comparative outputs.

Further, since the comparative outputs can be forcibly switched ON or OFF with key operation, without actually applying pressure, this mode is suitable for an operation check or a start-up check.

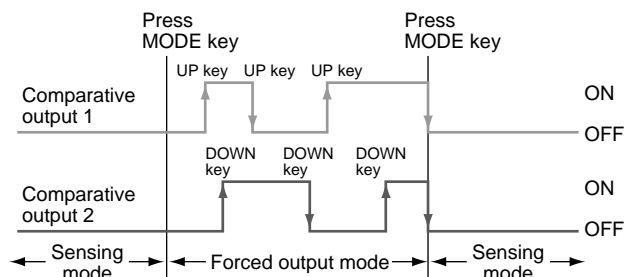

**Equipped with auto-reference and remote zero-adjustment functions.**

**More accurate pressure control with minimal effort.**

When the reference pressure of the device changes, the auto-reference function corrects the threshold level by being shifted by amount equal to the pressure change and the remote zero-adjustment function resets the display value to zero via external input. These functions are ideal for places where the reference pressure fluctuates wildly, or where you want complete control over delicate settings.

Example: When leak test mode is applied, Comparative Output 1 performs pressure load sensing and Comparative Output 2 determines the leak threshold.

Without auto-reference and remote zero-adjustment functions

Mode: Leak test mode  
 Comparative output 1 (Setting; lower limit...15/upper limit...20)  
 Comparative output 2 (Setting; lower limit...25/upper limit...30)

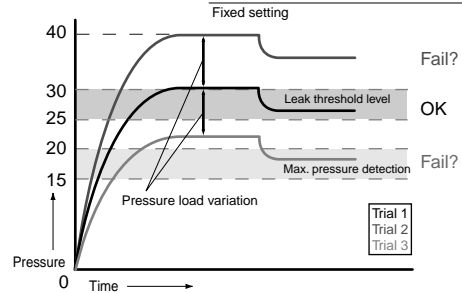

Because the threshold is fixed for conventional pressure sensors, changes in the original pressure are not handled correctly.

With auto-reference function applied

Comparative output 1 (Setting; lower limit...15/upper limit...20)  
 Comparative output 2 (Setting; lower limit...-5/upper limit...0)  
 Sets the absolute threshold level

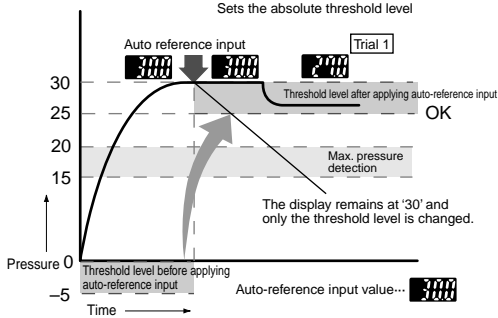

When auto-reference input is applied, the reference pressure '30' is added to the threshold level. If the reference pressure changes to '20' or '40', the auto-reference input compensates for this every time the reference pressure changes, so any variation in the max. pressure can be ignored.

With remote zero-adjustment function applied

Mode: Leak test mode

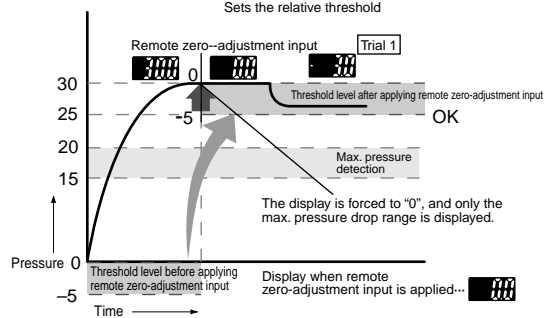

Comparative output 1 (Setting; lower limit...15/upper limit...20)  
 Comparative output 2 (Setting; lower limit...-5/upper limit...0)  
 Sets the relative threshold



When remote zero-adjustment input is applied, the reference pressure is forced to '0'. If the reference pressure changes to '20' or '40', the remote zero-adjustment input the standard pressure is adjusted to '0' every time the reference pressure changes, so any variation in the max. pressure can be ignored.

# ORDER GUIDE

## Pressure sensor head

Type	Appearance	Rated pressure range(Note)	Model No.	Pressure port	Applicable fluid
Vacuum pressure		0 to - 101.3kPa	<b>UZU511</b>	M5 female thread	Non-corrosive gas
			<b>UZU512</b>	R (PT) 1/8 male thread/M5 female thread	
			<b>UZU513</b>	NPT1/8 male thread/10-32UNF female thread	
			<b>UZU514</b>	10-32UNF male thread	
Positive pressure		0 to 1.000MPa	<b>UZU521</b>	M5 male thread	
			<b>UZU522</b>	R (PT) 1/8 male thread/M5 female thread	
			<b>UZU523</b>	NPT1/8 male thread/10-32UNF female thread	
Compound pressure		-100.0 to 100.0kPa	<b>UZU531</b>	M5 male thread	
			<b>UZU532</b>	R (PT) 1/8 male thread/M5 female thread	
			<b>UZU533</b>	NPT1/8 male thread/10-32UNF female thread	

Note: The rated pressure range indicates the range for full product performance.

## Pressure sensor controller

Appearance	Rated pressure range (Note)	Model No.	Output
	Vacuum pressure: 0 to -101.3kPa Positive pressure: 0 to 1.000MPa Compound pressure: -100.0 to +100.0kPa	<b>UZU41A</b>	NPN open-collector transistor
		<b>UZU415A</b>	PNP open-collector transistor

Note: The rated pressure range indicates the range for full product performance. It changes automatically according to the connected pressure sensor head.

Be sure to use an optional intermediate cable to connect the pressure sensor controller and the pressure sensor head.

## Intermediate cable

Designation	Appearance	Model No.	Description
Intermediate cable		<b>UZU5801</b>	Length: 2m 6.560ft
		<b>UZU5802</b>	Length: 3m 9.843ft
		<b>UZU5803</b>	Length: 5m 16.404ft
		<b>UZU5811</b>	Length: 2m 6.560ft
		<b>UZU5812</b>	Length: 3m 9.843ft
		<b>UZU5813</b>	Length: 5m 16.404ft
			4-core cable with connector at both ends
			4-core flexible cable with connector at both ends

## Panel mounting bracket (accessory)

**UZU3801**

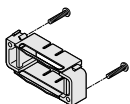

## OPTIONS

Designation	Model No.	Description
Connector	<b>UZU4810</b>	Set of 10 housings and 60 connector pins
6-core cable with connector	<b>UZU4811</b>	Length: 2m 6.560ft 0.2mm <sup>2</sup> 6-core cabtyre cable with connector Cable outer diameter: 4.8mm dia. .189inch dia.
DIN rail mounting bracket	<b>UZU3802</b>	For installation to 35mm 1.378inch width DIN rail
Controller mounting bracket	<b>UZU3803</b>	Vertical mounting bracket
	<b>UZU3804</b>	Horizontal mounting bracket

### Connector

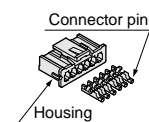

### 6-core cable with connector

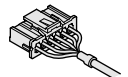

### DIN rail mounting bracket

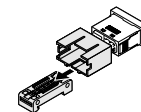

### Controller mounting bracket

• **UZU3803**

• **UZU3804**

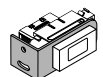

# SPECIFICATIONS

## Pressure sensor head

Type		Vacuum pressure				Positive pressure			Compound pressure		
		- 101kPa type				1MPa type			±100kPa type		
Item	Model No.	UZU511	UZU512	UZU513	UZU514	UZU521	UZU522	UZU523	UZU531	UZU532	UZU533
Type of pressure		Gauge pressure									
Rated pressure range (Note)		0 to - 101.3kPa				0 to 1.000MPa			-100.0 to 100.0kPa		
Pressure withstandability		500kPa				1.500MPa			500kPa		
Applicable fluid		Non-corrosive gas									
Supply voltage		12 to 24V DC $\pm 10\%$ Ripple P-P 10% or less									
Current consumption		15mA or less (operation indicator off) / 17mA or less (operation indicator on)									
Analog voltage output		<ul style="list-style-type: none"> <li>Output voltage: 1 to 5V (over rated pressure range)</li> <li>Zero point: within 1V<math>\pm 2\%</math>F.S. (vacuum/positive pressure type) within 3V<math>\pm 3\%</math>F.S. (compound pressure type)</li> <li>Span: within 4V<math>\pm 3.5\%</math>F.S.</li> <li>Linearity: within <math>\pm 1\%</math>F.S.</li> <li>Output impedance: 1k<math>\Omega</math> approx.</li> </ul>									
Environmental resistance	Pollution degree	3 (Industrial environment)									
	Protection	IP40 (IEC)									
	Ambient temperature	0 to + 50°C +32 to + 122°F (No dew condensation), Storage: -10 to + 60°C +14 to + 140°F									
	Ambient humidity	35 to 85% RH, Storage: 35 to 85% RH									
	EMC	Emission: EN50081-2, Immunity: EN50082-2									
	Voltage withstandability	1,000V AC for 1 min. between all supply terminals connected together and enclosure									
	Insulation resistance	50M $\Omega$ or more, with 500V DC megger									
	Vibration resistance	10 to 500Hz frequency, 3mm amplitude, or 5G in X, Y and Z directions for two hours each									
Shock resistance	1000m/s <sup>2</sup> acceleration in X, Y and Z directions for three times each										
Operation indicator		Orange LED [lights up when Comparative Output 1 is ON (only in case of connection to the DP5 series pressure controller)]									
Temperature characteristics		Over ambient temperature range +10 to +40°C +50 to +104°F: within $\pm 1\%$ F.S. of detected pressure at +25°C +77°F Over ambient temperature range 0 to +50°C +32 to +122°F: within $\pm 3\%$ F.S. of detected pressure at +25°C +77°F									
Voltage characteristics		Within $\pm 0.5\%$ F.S. for $\pm 10\%$ fluctuation of the supply voltage									
Pressure port		<b>UZU5□1:</b> M5 male thread (for installing gasket), <b>UZU5□2:</b> R $\frac{1}{8}$ male thread/M5 female thread <b>UZU5□3:</b> NPT $\frac{1}{8}$ male thread/10-32UNF female thread, <b>UZU514:</b> 10-32UNF male thread (for installing gasket)									
Material		Enclosure: PBT, Pressure port: Brass (nickel plated) (however, SUS303 in case of UZU5*1)									
Connecting method		Connector									
Cable		0.2mm <sup>2</sup> 4-core connector attached cabtyre cable, 100mm 3.937inch long									
Cable extension		Extension up to total 10m 32.808ft. is possible with 0.3mm <sup>2</sup> , or more, cable.									
Weight		<b>UZU5□1, UZU514:</b> 6g 0.21oz approx. <b>UZU5□2:UZU5□3:</b> 10g 0.35oz approx.									
Accessories		Gasket ( <b>UZU5□1, UZU514</b> , only)									

Notes: 1) The rated pressure range indicates the range for full product performance.

2) The pressure sensor head can be used independently.

## Pressure sensor controller

Item	Type	NPN output type	PNP output type
	Model No.	UZU41A	UZU41A
Applicable pressure sensor head	<b>UZU511, UZU521, UZU531, UZU512, UZU522, UZU532, UZU513, UZU523, UZU533, UZU514</b>		
Rated pressure range (Note 1)	Vacuum pressure: 0 to -101.3kPa, Positive pressure: 0 to 1.000MPa, Compound pressure: -100.0 to 100.0kPa		
Set Pressure range (Note 1)	Vacuum pressure: 101.3 to -101.3kPa (1.033 to -1.033kgf/cm <sup>2</sup> , 14.70 to -14.70psi, 1.013 to -1.013bar, 760 to -760mmHg, 29.9 to -29.9inHg), Positive pressure: -1.050 to 1.050MPa (-10.71 to 10.71kgf/cm <sup>2</sup> , -152.2 to 152.2psi, -10.50 to 10.50bar), Compound pressure: -199.9 to 199.9kPa (-1.999 to 1.999kgf/cm <sup>2</sup> , -19.98 to 19.98psi, -1.999 to 1.999bar, -1510 to 1537mmHg, -59.4 to 60.5inHg)		
Supply voltage	12 to 24V DC $\pm\frac{10}{15}$ % Ripple P-P 10% or less		
Current consumption	60mA or less (not including pressure sensor head)		
Sensor supply voltage	Same as supply voltage		
Comparative output (Comparative Output 1 Comparative Output 2)	NPN open-collector transistor (2 outputs) • Maximum sink current: 100mA • Applied voltage: 30V DC or less (between comparative output and 0V) • Residual voltage: 1V or less (at 100mA sink current) 0.4V or less (at 16mA sink current)		PNP open-collector transistor (2 outputs) • Maximum source current: 100mA • Applied voltage: Same as supply voltage (between comparative output and +V) • Residual voltage: 2V or less (at 100mA source current)
	Utilization category	DC-12 or DC-13	
	Output operation	NO/NC selectable by key operation	
	Output modes	Equipped with 4 types of modes: hysteresis mode, window comparator mode, leak test mode, forced output mode (selectable by key operation)	
	Hysteresis	1digit (however, variable in hysteresis mode, variable for comparative output 1 only when using leak test mode)	
	Repeatability	With vacuum/positive pressure type sensor head: within $\pm 0.2\%$ F.S. $\pm 1$ digit ( $\pm 3$ digits) With compound pressure type sensor head: within $\pm 0.2\%$ F.S. $\pm 2$ digits ( $\pm 6$ digits)	
	Response time	1ms, 16ms, 128ms, 512ms or less selectable by key operation (however, set response time is +2ms when auto-reference/remote zero-adjustment input is applied)	
	Short-circuit protection	Incorporated	
Input	Pressure sensor head input	Input voltage range: 1 to 5V DC (over rated pressure range)	
	Auto-reference/Remote zero adjustment input	• Input condition: NPN non-contact input [operates in Low (fall) state] • Signal condition: High...5 to 30V, or open Low...0.4V or less Low level input time...2ms or more	• Input condition: PNP non-contact input [operates in High (rise) state] • Signal condition: High...5 to 30V Low...0.4V or less, or open High level input time...2ms or more
Analog voltage output	<ul style="list-style-type: none"> <li>Output voltage: 1 to 5V DC (over rated pressure range)</li> <li>Zero point: within <math>1V \pm 2.5\%</math> F.S. (vacuum/positive pressure type)</li> <li>Span: within <math>3V \pm 3.5\%</math> F.S. (compound pressure)</li> <li>Linearity: within <math>\pm 1\%</math> F.S.</li> <li>Output impedance: 1k<math>\Omega</math> approx.</li> </ul>		
Display	3 1/2 digit LCD display (with red and green backlight) (Sampling rate : 256ms, 512ms, 1,024ms selectable by key operation)		
Display	Displayable pressure range	Vacuum pressure: 5.1 to -101.3kPa (0.052 to -1.033kgf/cm <sup>2</sup> , 0.74 to -14.70psi, 0.051 to -1.013bar, 38 to -760mmHg, 1.5 to -29.9inHg), Positive pressure: -0.050 to 1.050MPa (-0.51 to 10.71kgf/cm <sup>2</sup> , -7.2 to 152.2psi, -0.50 to 10.50bar), Compound pressure: -101.3 to 105.0kPa (-1.033 to 1.071kgf/cm <sup>2</sup> , -14.70 to 15.22psi, -1.013 to 1.050bar, -760 to 787mmHg, -29.9 to 31.0inHg)	
	Operation display	LCD segments is red when comparative output is ON, and green when it is OFF (output is selected via supplementary settings)	
Analog bar display	Bar display in steps of 14% F.S. approx.		
Operation indicator	Orange LED (lights up when Comparative Output 1 is ON), Green LED (lights up when Comparative Output 2 is ON)		
Environmental resistance	Pollution degree	3 (Industrial environment)	
	Protection	IP40 (IEC)	
	Ambient temperature	0 to +50°C +32 to +122°F (No dew condensation), Storage: -10 to +60°C +14 to +140°F	
	Ambient humidity	35 to 85% RH, Storage: 35 to 85% RH	
	EMC	Emission: EN50081-2, Immunity: EN50082-2	
	Voltage withstandability	1,000V AC for 1 min. between all supply terminals connected together and enclosure	
	Insulation resistance	50M $\Omega$ or more, with 500V DC megger between all supply terminals connected together and enclosure	
	Vibration resistance	10 to 150Hz frequency, 0.75mm amplitude, or 5G in X, Y and Z directions for two hours each	
Shock resistance	100m/s <sup>2</sup> acceleration in X, Y and Z directions for three times each		
Temperature characteristics	Over ambient temperature range 0 to +50°C +32 to +122°F: within $\pm 0.5\%$ F.S. of detected pressure at +25°C +77°F (not including pressure sensor head)		
Material	Front case: ABS, LCD display section: PET, Rear case: PBT		
Connecting method	Connector		
Suitable cable	Conductor cross-section area (Note 2)	0.16 to 0.32mm <sup>2</sup> (AWG#25 to 22)	
	Lead wire diameter	$\phi 1.2$ to $\phi 1.8$ mm $\phi .047$ to $\phi .071$ inch	
	Wire material	Tin plated, soft, twisted copper wire	
Weight	20g 0.71oz approx.		
Accessories	Panel mounting bracket ( <b>UZU3801</b> ): 1 set, Connector: 1 set (Housing: 1 pc., Connector pin: 6 pcs., Pressure unit label: 1 pc., Connector cap: 1 pc.)		

Notes: 1) The rated pressure range indicates the range for full product performance. It changes automatically according to the connected pressure sensor head.  
2) If the wiring is longer than 2m 6.560ft, use a cable with a diameter of 0.3mm<sup>2</sup> or more.

# I/O CIRCUIT AND WIRING DIAGRAMS

## UZU41A

NPN output type

### I/O circuit diagram

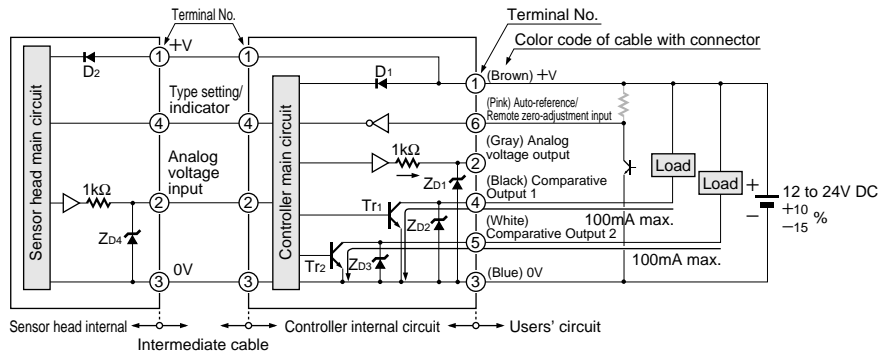

Symbols... D<sub>1</sub>, D<sub>2</sub>: Reverse supply polarity protection diode  
Z<sub>D1</sub> to Z<sub>D4</sub>: Surge absorption zener diode  
Tr<sub>1</sub>, Tr<sub>2</sub>: NPN output transistor

### Pin position

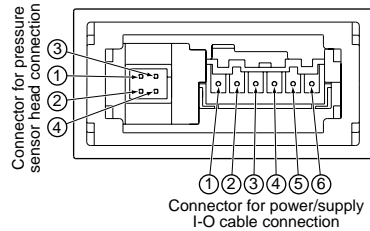

### Connector for power/ supply I-O cable connection

- ① +V
- ② Analog voltage output
- ③ 0V
- ④ Comparative Output 1
- ⑤ Comparative Output 2
- ⑥ Auto-reference/ remote zero-adjustment input

### For independent use of Sensor head

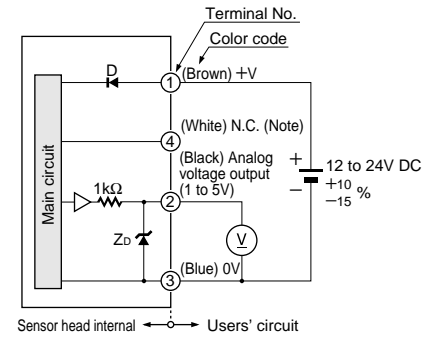

Note: In case the pressure sensor head is used independently, insulate the white wire (Terminal No.4) and keep it open.

Symbols... D: Reverse supply polarity protection diode  
Z<sub>D</sub>: Surge absorption zener diode

### Connector for pressure sensor head connection

- ① +V
- ② Analog voltage output
- ③ 0V
- ④ NC

## UZU415A

PNP output type

### I/O circuit diagram

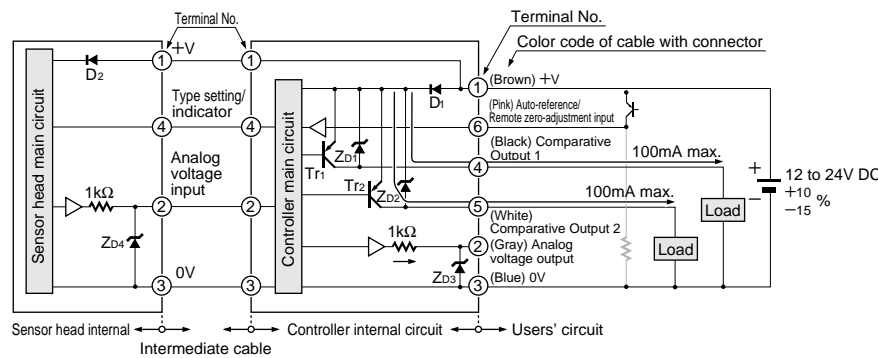

Symbols... D<sub>1</sub>, D<sub>2</sub>: Reverse supply polarity protection diode  
Z<sub>D1</sub> to Z<sub>D4</sub>: Surge absorption zener diode  
Tr<sub>1</sub>, Tr<sub>2</sub>: PNP output transistor

### Pin position

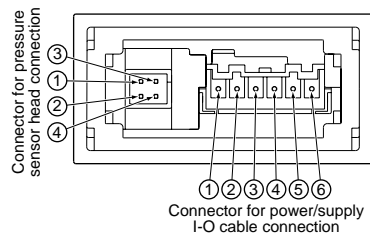

### Connector for power/ supply I-O cable connection

- ① +V
- ② Analog voltage output
- ③ 0V
- ④ Comparative Output 1
- ⑤ Comparative Output 2
- ⑥ Auto-reference/ remote zero-adjustment input

### Connector for pressure sensor head connection

- ① +V
- ② Analog voltage output
- ③ 0V
- ④ NC

# PRECAUTIONS FOR PROPER USE



- This product is not a safety sensor. Its use is not intended or designed to protect life and prevent body injury or property damage from dangerous parts of machinery. It is a normal pressure detection sensor.
- The **UZU5** series is designed for use with non-corrosive gas. It cannot be used with liquid or corrosive gas.

## Functional description

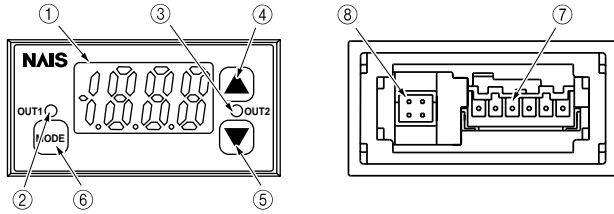

	Description	Function
①	3 1/2 digit LCD display (with red and green backlight)	<ul style="list-style-type: none"> <li>• Displays measured pressure, settings, error messages and key-protect status.</li> <li>• Its lighting up can be set as Red when ON/Green when OFF with respect to either Comparative Output 1 or Comparative Output 2, according to the backlight relation selection during the supplementary setting mode.</li> </ul>
②	Comparative Output 1 operation indicator (Orange)	<ul style="list-style-type: none"> <li>• Lights up when Comparative Output 1 is ON.</li> </ul>
③	Comparative Output 2 operation indicator (Green)	<ul style="list-style-type: none"> <li>• Lights up when Comparative Output 2 is ON.</li> </ul>
④	▲ key	<ul style="list-style-type: none"> <li>• In the initial setting mode and supplementary setting mode, pressing the key changes the setting item.</li> <li>• In the pressure value setting mode, pressing the key changes the set value.</li> <li>• In the sensing mode, pressing the key continuously for 4 sec., or more, displays the peak hold value.</li> </ul>
⑤	▼ key	<ul style="list-style-type: none"> <li>• In the initial setting mode and supplementary setting mode, pressing the key changes the set conditions.</li> <li>• In the pressure value setting mode, pressing the key changes the set value.</li> <li>• In the sensing mode, pressing the key continuously for 4 sec., or more, displays the bottom hold value.</li> </ul>
⑥	MODE key	<ul style="list-style-type: none"> <li>• In the pressure value setting mode, pressing the key changes the setting item.</li> <li>• In the sensing mode, pressing the key continuously for 4 sec., or more, can set/cancel the key-protect.</li> <li>• In the sensing mode, pressing both UP key and MODE key simultaneously changes the mode to the initial setting mode. Whereas, pressing both DOWN key and MODE key simultaneously changes the mode to the supplementary setting mode.</li> </ul>
⑦	Connector for power supply/I-O cable connection	<ul style="list-style-type: none"> <li>• It is the connector for connection of power supply/I-O cable.</li> </ul>
⑧	Connector for pressure sensor head connection	<ul style="list-style-type: none"> <li>• It is the connector for connection of pressure sensor head.</li> </ul>

## Error messages

- When an error occurs, take the following corrective action.

Error message	Cause	Corrective action	
	The controller, pressure sensor head and the intermediate cable are not correctly connected.	Connect the pressure sensor head and the intermediate cable correctly.	
	Pressure sensor head cable or intermediate cable have a cable break.	Check the pressure sensor head cable and the intermediate cable and replace the cable having a break.	
	The pressure sensor head is damaged.	Replace the pressure sensor head.	
	Overcurrent due to short-circuit.	Switch off the power supply and check the load.	
	Pressure is being applied during zero-point adjustment.	Applied pressure at the pressure port should be brought to atmospheric pressure and zero-point adjustment should be done again.	
	Positive pressure and compound pressure types	Applied pressure exceeds the upper limit of displayable pressure range.	Applied pressure should be brought within the rated pressure range.
	Vacuum pressure type	Applied pressure exceeds the lower limit (reverse pressure) of displayable pressure range.	
	Positive pressure and compound pressure types	Applied pressure exceeds the lower limit (reverse pressure) of displayable pressure range.	Applied pressure should be brought within the rated pressure range.
	Vacuum pressure type	Applied pressure exceeds the upper limit of displayable pressure range.	

## Wiring

- Make sure to carry out the wiring in the power supply off condition.
- Verify that the supply voltage variation is within the rating.
- If power is supplied from a commercial switching regulator, ensure that the frame ground (F.G.) terminal of the power supply is connected to an actual ground.
- In case noise generating equipment (switching regulator, inverter motor, etc.) is used in the vicinity of this sensor, connect the frame ground (F.G.) terminal of the equipment to an actual ground.
- If the used power supply generates a surge, connect a surge absorber to the power supply to absorb the surge.
- Do not run the wires together with high-voltage lines or power lines or put them in the same raceway. This can cause malfunction due to induction.
- In order to reduce noise, make the wiring as short as possible. Take care that wrong wiring will damage the sensor.

## Others

- Use within the rated pressure range.
- Do not apply pressure exceeding the pressure withstandability value. The diaphragm will get damaged and correct operation shall not be maintained.
- Do not use during the initial transient time (**UZU4**: 3 sec. approx., **UZU5**: 50ms approx.) after the power supply is switched on.
- Avoid dust, dirt, and steam.
- Take care that the sensor does not come in direct contact with water, oil, grease, or organic solvents, such as, thinner, etc.
- Do not insert wires, etc., into the pressure port. The diaphragm will get damaged and correct operation shall not be maintained.
- Do not operate the keys with pointed or sharp objects.

## Setting

- If key-protect has been set, make sure to release key-protect before operating the keys.  
[Please refer to 'Key-protect function' on P-3 for the procedure.]
- Pressure value setting can be done only if the output mode is set to the hysteresis mode, window comparator mode or the leak test mode. Pressure values cannot be set if the output mode is set to the forced output mode.
- Set Values P-1 to P-4 can be common for all the output modes.
- In the positive pressure type and the compound pressure type, Set Value P-2 can be set only towards the higher pressure side with respect to Set Value P-1 and Set Value P-4 can be set only towards the higher pressure side with respect to Set Value P-3. Further, in the vacuum pressure type, Set Value P-2 can be set only towards the higher vacuum side with respect to Set Value P-1 and Set Value P-4 can be set only towards the higher vacuum side with respect to Set Value P-3.
- The auto-reference function affects only Set Value P-3 and Set Value P-4.
- Set Value P-A is the pressure value when the auto-reference input or the remote zero-adjustment input is applied. When the auto-reference input or the remote zero-adjustment input is not applied, Set Value P-A is zero.
- The set conditions are written and stored into an EEPROM. However, note that the EEPROM has a life span and its guaranteed life is 100,000 write operation cycles. Further, since the auto-reference input value and the remote zero-adjustment input value are not stored in the EEPROM, they are not included in the number of write operation cycles.

### <Setting procedure>

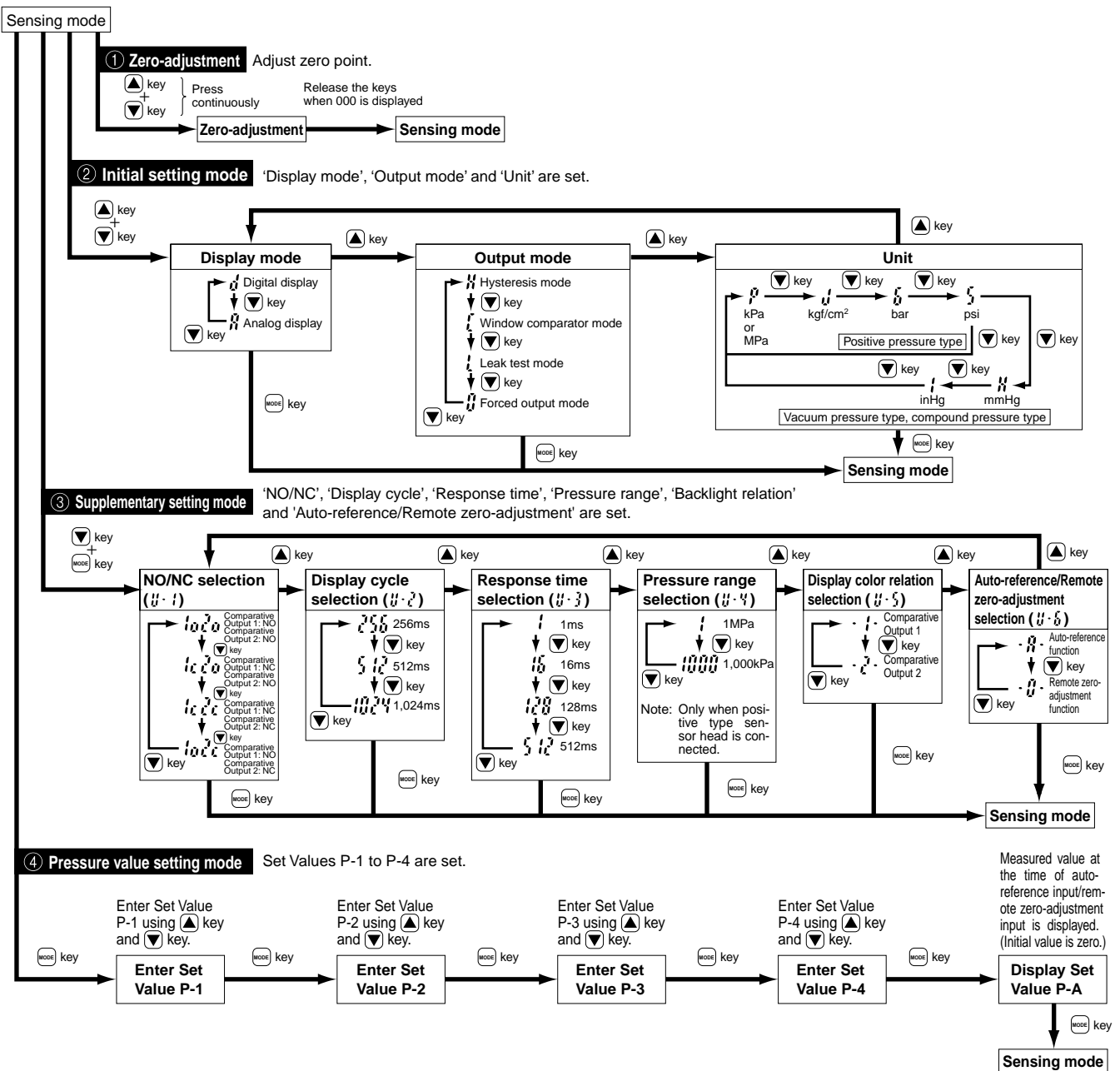

## Auto-reference function

- Auto-reference function corrects Set Value P-3 and Set Value P-4 of Comparative Output 2 by taking the pressure measured at the time of auto-reference input as the reference pressure.

### <Before auto-reference input>

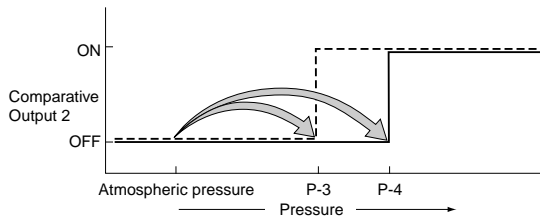

- When there is no auto-reference input, the atmospheric pressure is taken as the reference pressure for Set Value P-3 and Set Value P-4.

### <After auto-reference input>

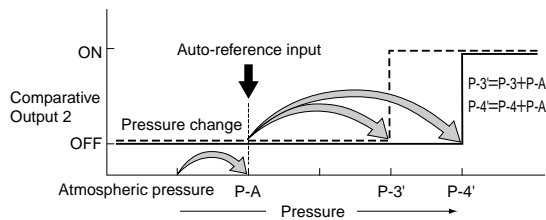

- At the time of auto-reference input, the pressure value detected at that instant is temporarily recorded as Set Value P-A and becomes the reference pressure.
- With Set Value P-A as the reference pressure, Set Value P-3 and Set Value P-4 are automatically corrected to 'Set Value P-3 + Set Value P-A' and 'Set Value P-4 + Set Value P-A', respectively.

### Settable range and set pressure range after correction

The settable range of Set Value P-3 and Set Value P-4 is wider than the rated pressure range to cater to the auto-reference function.

- At the time of auto-reference input, if the corrected set value exceeds the set pressure range, the set value is automatically corrected to be within the set pressure range. Hence, please see that the set pressure range is not exceeded.

## Operation chart

### <Normal operation (comparative outputs set to NO)>

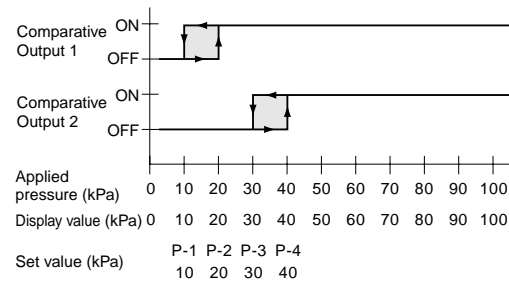

### <With auto-reference input (comparative outputs set to NO)>

- Auto-reference input: 50kPa
- Output mode: Hysteresis mode

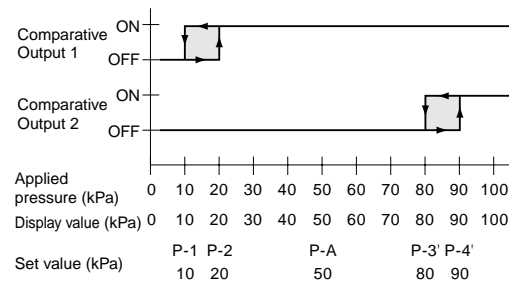

Note: As in the case of the hysteresis mode, Set Value P-3 and Set Value P-4 are shifted also in case the output is set to the window comparator mode or the leak test mode.

- Maintain the pressure at a constant level for at least 2ms after the auto-reference input is made Low (High in case of PNP output type). If used in a transient state, it will result in wrong operation.
- Use Comparative Output 2 at least 'set response time + 2ms' after the auto-reference input is made Low (High in case of PNP output type).
- At the time of auto-reference input,  $\square \frac{m}{}$  is displayed on the 3 $\frac{1}{2}$  digit display for 1 sec. approx.
- The auto-reference input value (Set Value P-A) becomes zero when the power supply is switched off and then on again.
- Although it is not possible to display the corrected Set Value P-3' and Set Value P-4', it is possible to display the auto-reference input value (Set Value P-A).

## Remote zero-adjustment function

- The remote zero-adjustment function forcibly sets the pressure value at the time of application of an external input signal to zero.

At the time of remote zero-adjustment input, the set values are not corrected. When using the remote zero-adjustment function, make sure that the pressure and the set values do not exceed the rated pressure range.

### Operation chart

#### <Normal operation (comparative outputs set to NO)>

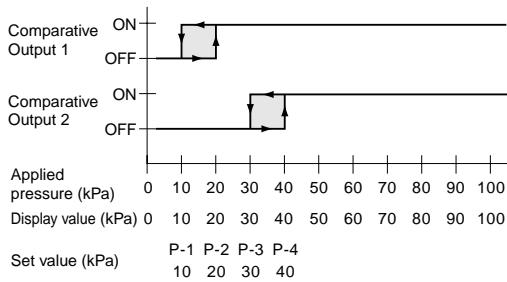

#### <With remote zero-adjustment input (comparative outputs set to NO)>

- Remote zero-adjustment input: 50kPa
- Output mode: Hysteresis mode

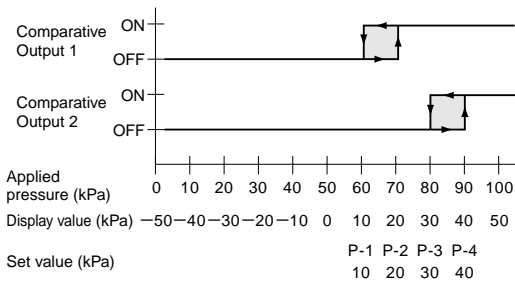

Note: As in the case of the hysteresis mode, the displayed values and the ON/OFF points of the output are shifted also in case the output mode is set to the window comparator mode.

- Remote zero-adjustment input: 50kPa
- Output mode: Leak test mode

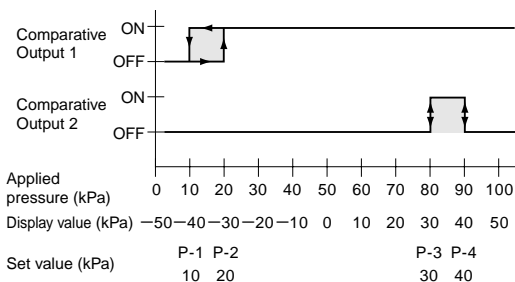

Note: In the leak test mode, the zero-adjustment function is applied only to Comparative Output 2. Comparative Output 1 operates with the atmospheric pressure as the reference.

- Maintain the pressure at a constant level for at least 2ms after the remote zero-adjustment input is made Low (High in case of PNP output type). If used in a transient state, it will result in wrong operation.
- Use the comparative outputs at least 'set response time + 2ms' after the remote adjustment input is made Low (High in case of PNP output type).
- At the time of remote zero-adjustment input,  $\frac{1}{10}$  is displayed on the  $3\frac{1}{2}$  digit display for 1 sec. approx.
- If the power supply is switched off and then on again, the remote zero-adjustment input value is cleared and the sensor

returns to normal operation with atmospheric pressure as the reference.

## Forced output mode

- In the initial setting mode, if the output mode is set to the forced output mode ( $\frac{1}{10}$ ), the comparative outputs are forcibly maintained at OFF level in the sensing mode, irrespective of Set Values P-1 to P-4.

Further, if the keys are operated as per the procedure given below, the comparative outputs can be forcibly switched either ON or OFF without applying pressure at the pressure port.

This is convenient for an operation check of the comparative outputs or for an inspection before commencing work.

The diagram below appears when the **UZU41A** has been used to set the display to 'Digital display' ( $\frac{1}{10}$ ).

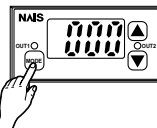

- In the sensing mode, press  $\text{MODE}$  key to change to the forced output mode.
- Each time  $\uparrow$  key is pressed, Comparative Output 1 switches to ON and OFF, alternately. Each time  $\downarrow$  key is pressed, Comparative Output 2 switches to ON and OFF, alternately.
- Press  $\text{MODE}$  key to return to the sensing mode.

- Output is kept off at the point where the mode is changed from another output mode to forced output control mode ( $\frac{1}{10}$ ).
- Even if output has been set to stay on during forced output control mode, it will be forcibly changed to off at the point where the mode changes back to sensing mode.

## Peak hold & bottom hold functions

- Peak hold and bottom hold functions enable the display of the peak value and the bottom value.
- These functions are convenient for finding the pressure variation range or determining the reference for pressure setting.

Please note that the peak value and the bottom value data is erased when it is no longer displayed.

### Peak hold display

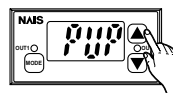

Displayed alternately

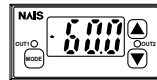

- In the sensing mode, keep  $\uparrow$  key pressed until  $\frac{P10}{10}$  is displayed. (4sec. or more)
- When the finger is released after  $\frac{P10}{10}$  is displayed, the peak value and  $\frac{P10}{10}$  are displayed alternately.
- Press  $\uparrow$  key
  - If the applied pressure exceeds the displayable pressure range, error message ( $\frac{...}{10}$  or  $\frac{...}{10}$ ) and  $\frac{P10}{10}$  are displayed alternately. In this case, bring back the applied pressure to within the rated pressure range.
  - The figure on the left shows the display of a vacuum type sensor

### Bottom hold display

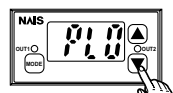

Displayed alternately

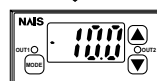

- In the sensing mode, keep  $\downarrow$  key pressed until  $\frac{P10}{10}$  is displayed. (4sec. or more)
- When the finger is released after  $\frac{P10}{10}$  is displayed, the bottom value and  $\frac{P10}{10}$  are displayed alternately.
- Press  $\downarrow$  key
  - If the applied pressure exceeds the displayable pressure range, error message ( $\frac{...}{10}$  or  $\frac{...}{10}$ ) and  $\frac{P10}{10}$  are displayed alternately. In this case, bring back the applied pressure to within the rated pressure range.
  - The figure on the left shows the display of a vacuum type sensor

## Key-protect function

- Key-protect is a function which prevents any unintentional change in the conditions which have been entered in each setting mode by making the sensor not to respond to the key operations.

### Setting of key-protect

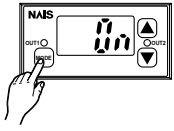

- In the sensing mode, press **MODE** key continuously for about 4sec. or more and, release it immediately when **0.00** is displayed.
- Key-protect is set and the sensor returns to the sensing mode.

- Since the key-protect information is stored in an EEPROM, it is not erased even if the power supply is switched off.
- Please take care to remember if the key-protect function has been set.

### Release of key-protect

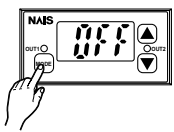

- In the sensing mode, press **MODE** key continuously for about 4sec. or more, and release it immediately when **0.00** is displayed.
- Key-protect is released and the sensor returns to the sensing mode.

- When the keys are to be operated, make sure that key-protect is released.

## Piping

- When connecting a commercial coupling to the pressure port, hold the hexagonal section of the pressure port with a 11mm .433inch (**UZU5□2**, **UZU5□3**: 12mm .472inch) spanner, and make sure that the tightening torque is 1N·m (male thread type of **UZU5□2**, **UZU5□3**: 5N·m) or less. If excessive tightening torque is applied, the M5 male thread of the commercial coupling or the pressure port will get damaged.

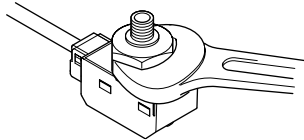

## Connecting

- To connect the pressure sensor head to the pressure controller, the optional intermediate cable (**UZU580□**) must be used.
- Stress should not be applied to the sensor cable joint and the part of connector.
- If the pressure sensor head is to be mounted on a movable part, make sure to use a flexible intermediate cable.
- When connecting the intermediate cable to the pressure controller, make sure to fit the connector cap, supplied as an accessory with the pressure controller, by sliding it as shown in the figure below. If the connector cap is not fitted, there is a danger of the intermediate cable getting disconnected from the sensor.

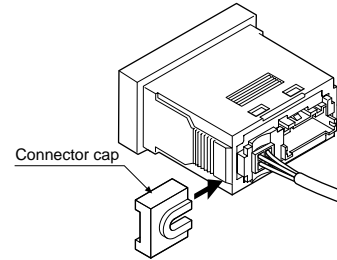

## Mounting

- Install the enclosed panel mounting bracket (**UZU3801**) as shown in the figure below. The tightening torque should be 0.15N·m or less. Further, tighten both the right and the left screw gradually and equally, so that the panel mounting bracket does not tilt.

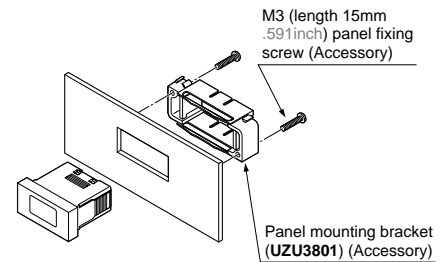

## DIMENSIONS (Unit: mm inch)

**UZU41A**  
**UZU415A**

Pressure controller

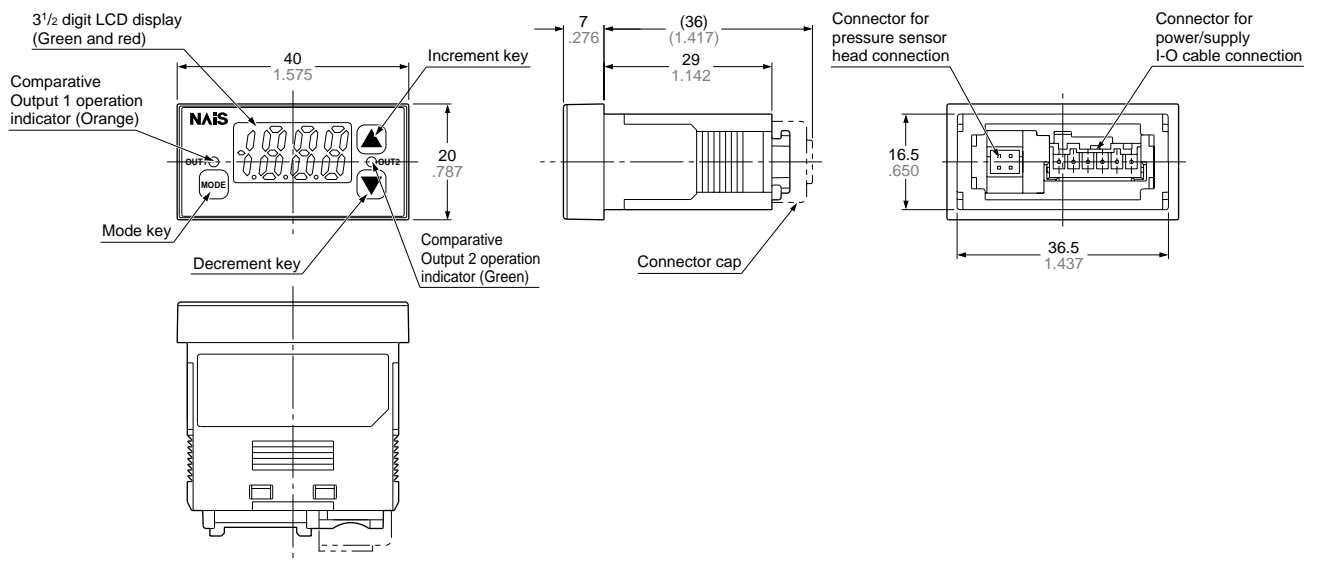

**UZU5□1**  
**UZU514**

Sensor head

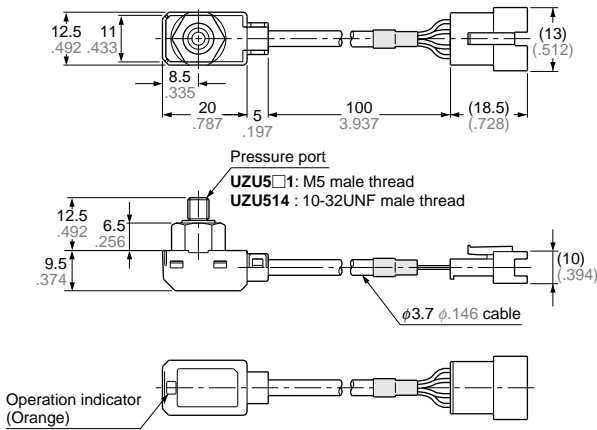

**UZU5□2**  
**UZU5□3**

Sensor head

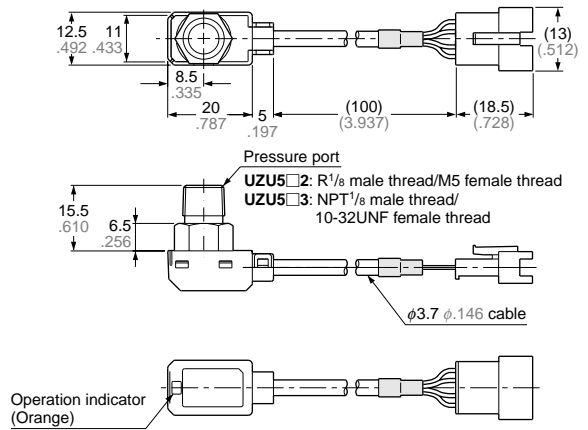

**UZU3801**

Panel mounting bracket (Accessory)

Assembly dimensions

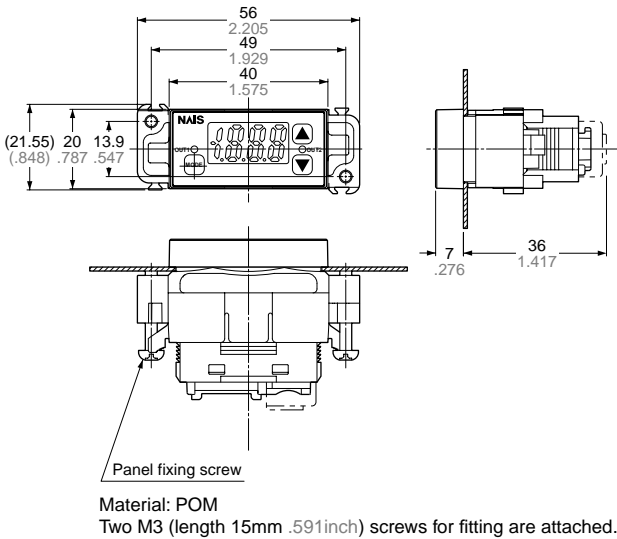

Panel cut-out dimensions

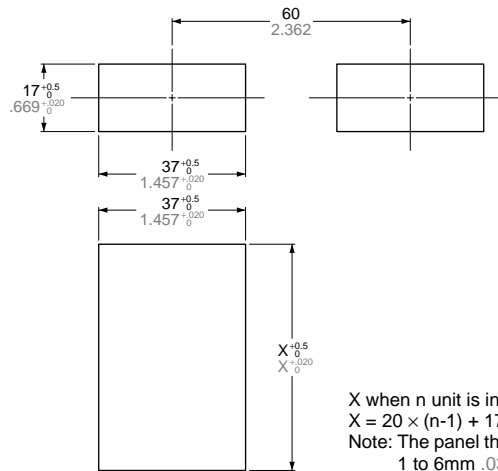

**UZU580**  
**UZU581**

Intermediate cable (Optional)

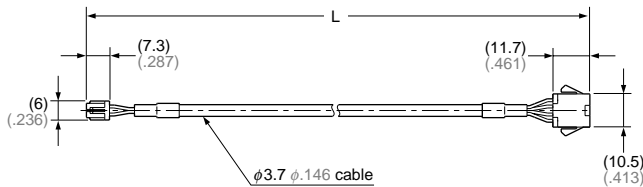

Note: The heat-shrink tube for the standard cable is black, and the heat-shrink tube for the flexible cable is gray.

Model No.	L (Cable length)
<b>UZU58□1</b>	2m 6.560ft
<b>UZU58□2</b>	3m 9.843ft
<b>UZU58□3</b>	5m 16.404ft

## UZU3802 DIN rail mounting bracket (optional)

### Assembly dimensions

#### <Horizontal mounting>

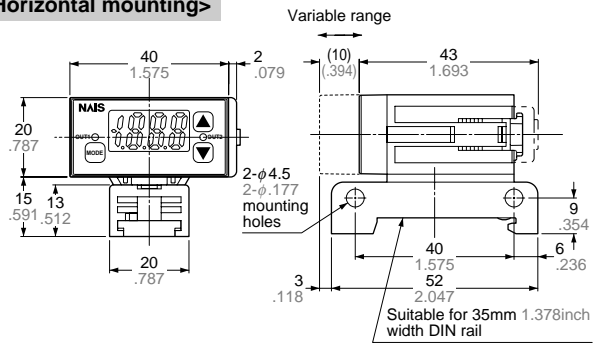

#### <Vertical mounting>

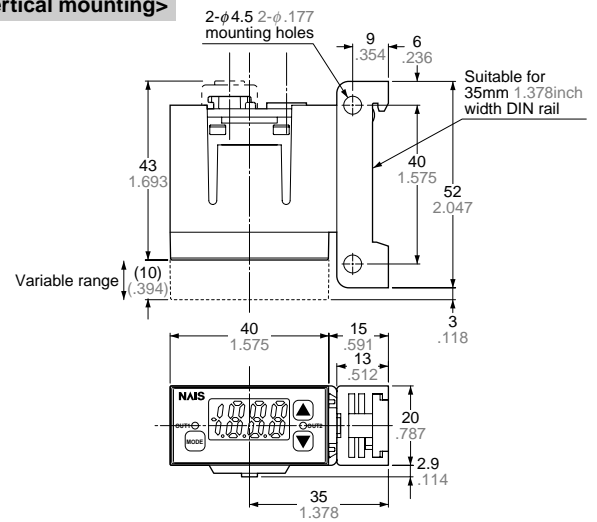

## UZU3803 Controller mounting bracket (Optional)

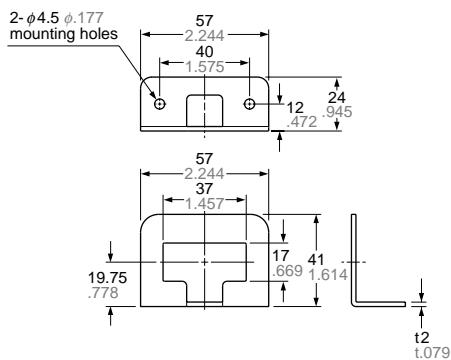

Material: cold rolled carbon steel (SPCC)  
(Uni-chrome plated)

Note: Use together with panel mounting bracket included with sensor.

## UZU3804 Controller mounting bracket (Optional)

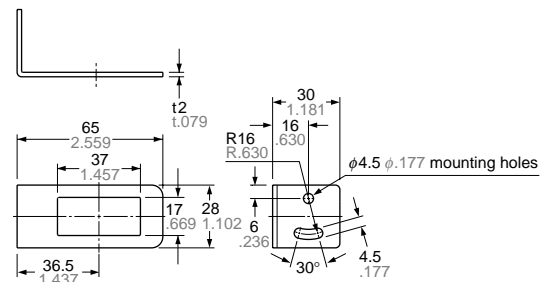

Material: cold rolled carbon steel (SPCC)  
(Uni-chrome plated)

Note: Use together with panel mounting bracket included with sensor.

## UZU4810 Connector (Optional)

#### <Housing>

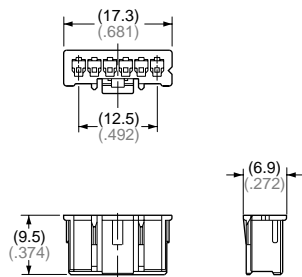

#### <Connector pin>

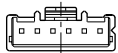
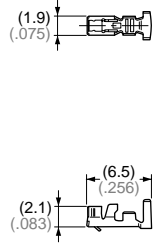

Connector  
Connector pin: BXA-001T-P0.6 manufactured by  
J. S. T. MFG CO., LTD.  
Housing: XAP-06V-1 manufactured by  
J. S. T. MFG CO., LTD.  
Crimping tool: YC-690R manufactured by  
J.S.T. MFG CO., LTD.

## UZU4811 Cable with connector(Optional)

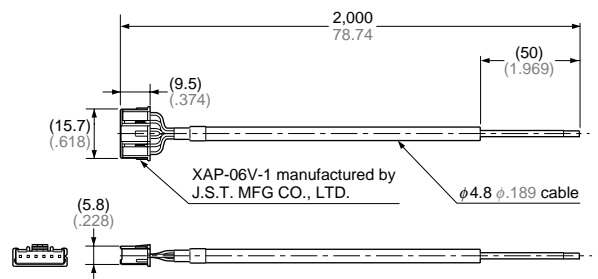

# GLOBAL NETWORK

## Europe

<http://www.mew-europe.com/>

### ■ Germany

**Matsushita Electric Works (Europe) AG**  
Rudolf-Diesel-Ring 2, D-83607 Holzkirchen, Germany  
Tel: 49-8024-648-0

### Germany

Matsushita Electric Works Deutschland G.m.b.H.

### United Kingdom

Matsushita Electric Works UK Ltd.

### • Ireland

Matsushita Electric Works UK Ltd. Irish Branch Office

### Austria

Matsushita Electric Works Austria G.m.b.H.

### Switzerland

Matsushita Electric Works Schweiz AG

### France

Matsushita Electric Works France S.A.R.L.

### Italy

Matsushita Electric Works Italia s.r.l.

### Benelux

Matsushita Electric Works Benelux B.V.

### Spain

Matsushita Electric Works España S.A.

### • Portugal

Matsushita Electric Works España S.A. Portuguese Branch Office

### Czech

Matsushita Electric Works (CZ) s.r.o.

### Scandinavia

Matsushita Electric Works Scandinavia AB

## North & South America

<http://www.aromat.com/acsd>

### ■ USA

#### Aromat Corporation

629 Central Ave., New Providence, N.J. 07974 U.S.A.  
Tel: 1-908-464-3550 (Headquarter)

- New Jersey
- Georgia
- Massachusetts
- Illinois
- Texas
- California
  - Los Angeles
  - San Jose
- Michigan
- Canada

Aromat Canada, Inc.

## Representative Office

- Indonesia
- Vietnam
- Philippines
- India
- Turkey
- Brazil

## Asia

### ■ Singapore

#### Matsushita Electric Works (Asia Pacific) Pte. Ltd.

101 Thomson Road, #25-03/05, United Square, Singapore 307591  
Tel: 65-255-5473

### Malaysia

Matsushita Electric Works (Malaysia) Sdn. Bhd.

### Thailand

Matsushita Electric Works Sales (Thailand) Co., Ltd.

### U.A.E.

Matsushita Electric Works (Middle East) FZE.

### ■ China

#### Matsushita Electric Works (China) Co., Ltd.

Suite 201 Level 2 Tower W3, The Toners, Oriental Plaza, No. 1, East Chang An Ave., Dong Cheng District, Beijing, 100005 China  
Tel: 86-10-8518-1302, 1303

### Beijing

Matsushita Electric Works (China) Co., Ltd.

### Shanghai

Matsushita Electric Works (China) Co., Ltd. Shanghai Branch Office

### Guangzhou

Matsushita Electric Works (China) Co., Ltd. Guangzhou Branch Office

### Dalian

Matsushita Electric Works (China) Co., Ltd. Dalian Branch Office

### Shenzhen

Matsushita Electric Works (China) Co., Ltd. Shenzhen Branch Office

### Chengdu

Matsushita Electric Works (China) Co., Ltd. Chengdu Branch Office

### ■ Hong Kong

#### Matsushita Electric Works (Hong Kong), Ltd.

Rm1601, 16/F, Tower 2,  
The Gateway, 25 Canton Road,  
Tsimshatsui, Kowloon, Hong Kong  
Tel: 852-2529-3956

### ■ Japan

#### Matsushita Electric Works, Ltd.

Automation Controls Company  
1048, Kadoma, Kadoma-shi, Osaka 571-8686, Japan  
Tel: 81-06-6908-1050

These materials are printed on ECF pulp.

These materials are printed with earth-friendly vegetable-based (soybean oil) ink.



Please contact .....

## Aromat Corporation

Automation Controls Sales Division

■ Headquarters: 629 Central Avenue, New Providence, NJ 07974 USA

■ Sales Assistance: 1 (800) 228-2350

■ Technical Support: 1 (877) NAIS-TSC (1-877-624-7872)

<http://www.aromat.com/acsd>

COPYRIGHT © 2001 All Rights Reserved